

V Street, SW

Roof Plan (roof of penthouse)

EXTENSIVE GREEN ROOF SYSTEM

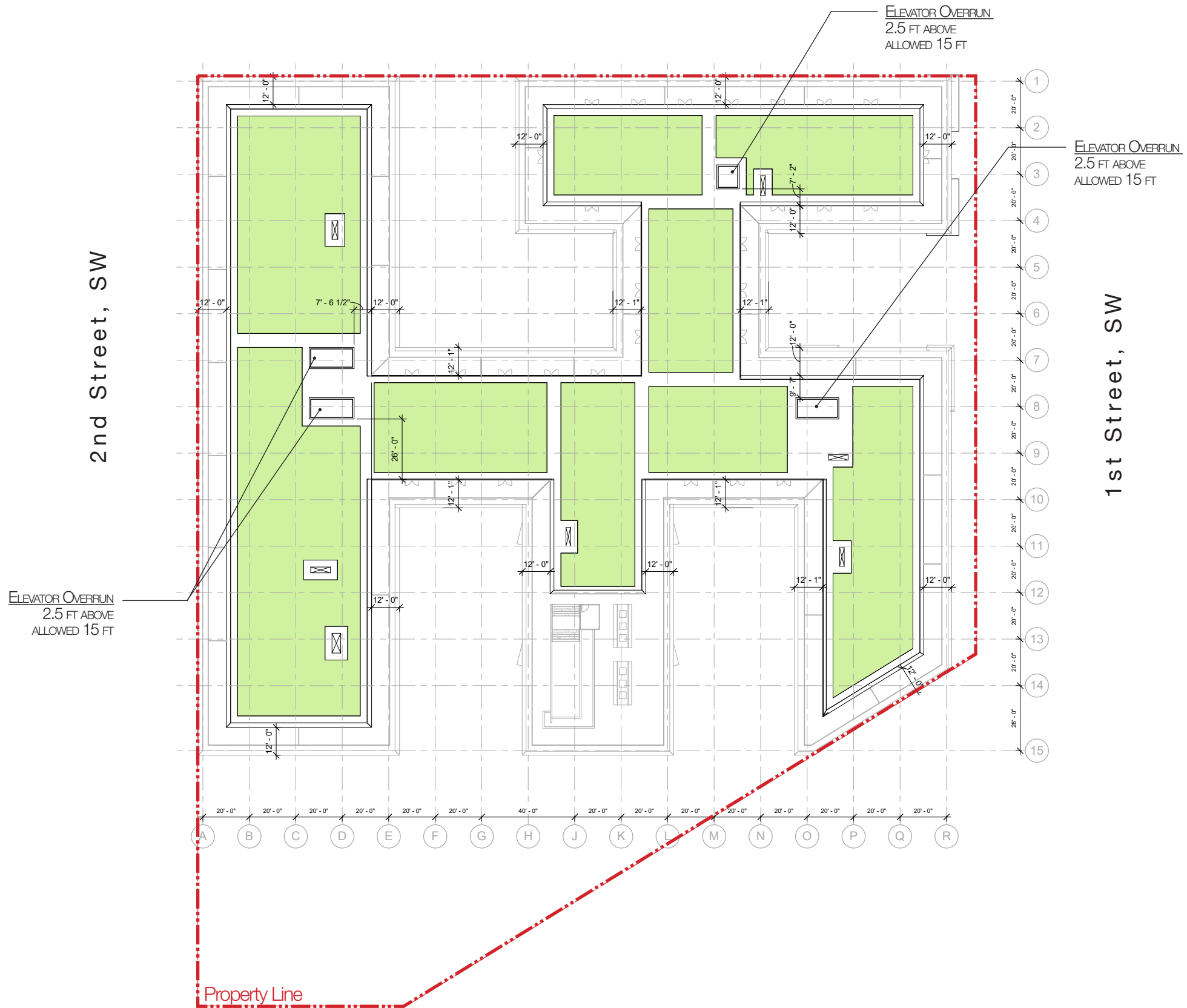
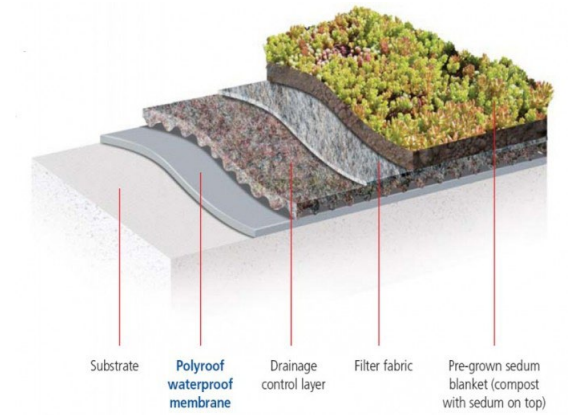

2nd Street, SW

1st Street, SW

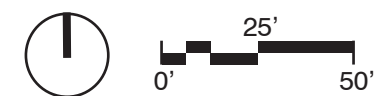

River Point - 2100 2nd St, SW

Square 613 / Lot 10

Roof of Penthouse

ZONING COMMISSION
District of Columbia
May 16, 2017
EXHIBIT NO. 27A2





River Point - 2100 2nd St, SW

Square 613 / Lot 10

Penthouse - 3d Rendering

June 2, 2017



A48

Residential Levels

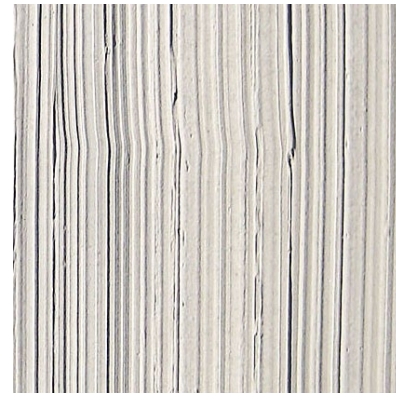

Precast Concrete
with Custom Formliner
[Reckli]

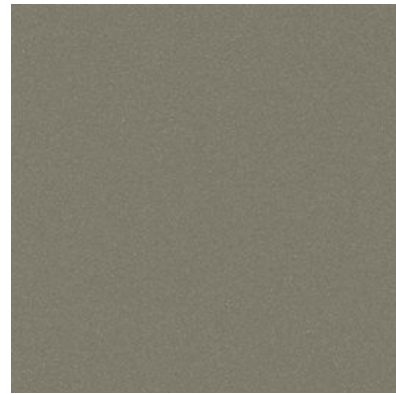

ACM Panel
Paint: [PPG - Duranar XL -
Summer Suede Metallic]



High-Density Fiber Cement
Panel Rainscreen System
[EQUITONE]

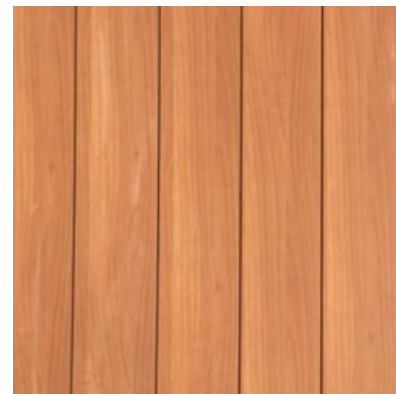

Phenolic Resin Board
Rainscreen System
[TRESPA - Meteon]



ACM Panel
Paint: [PPG - Duranar XL -
Cina Gold]



Glass Railing



Corrugated Aluminium Siding
[CENTRIA - Concept Series]



Aluminium Window Wall System:
[Kawneer FG501T]
Glass: [Vitro - Solarban 67]

Retail Level

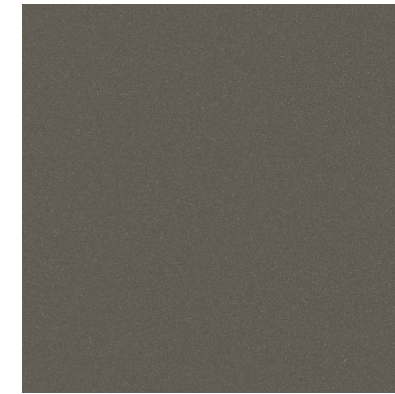

ACM Panel
[Reynobond - Classic Bronze]

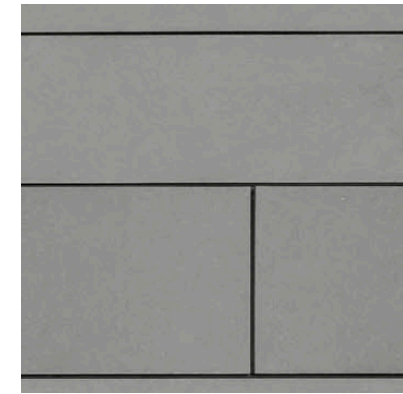

High-Density Fiber Cement
Panel Rainscreen System
[EQUITONE]



ACM Panel
[Reynobond - Aciero Corten]



Natural Stone
Rainscreen System
[Rugo Stone]



Aluminium Sectional Door w/
Glass Panels
[Overhead Door - 521]



Aluminium Storefront System:
[Kawneer 1600]
Glass: [Vitro - Solarban R100]



River Point - 2100 2nd St, SW

Square 613 / Lot 10

Rendering - Bird's Eye View

June 2, 2017



A51



River Point - 2100 2nd St, SW

Square 613 / Lot 10

Rendering - 1st Street (Northeast Corner)

June 2, 2017



A52

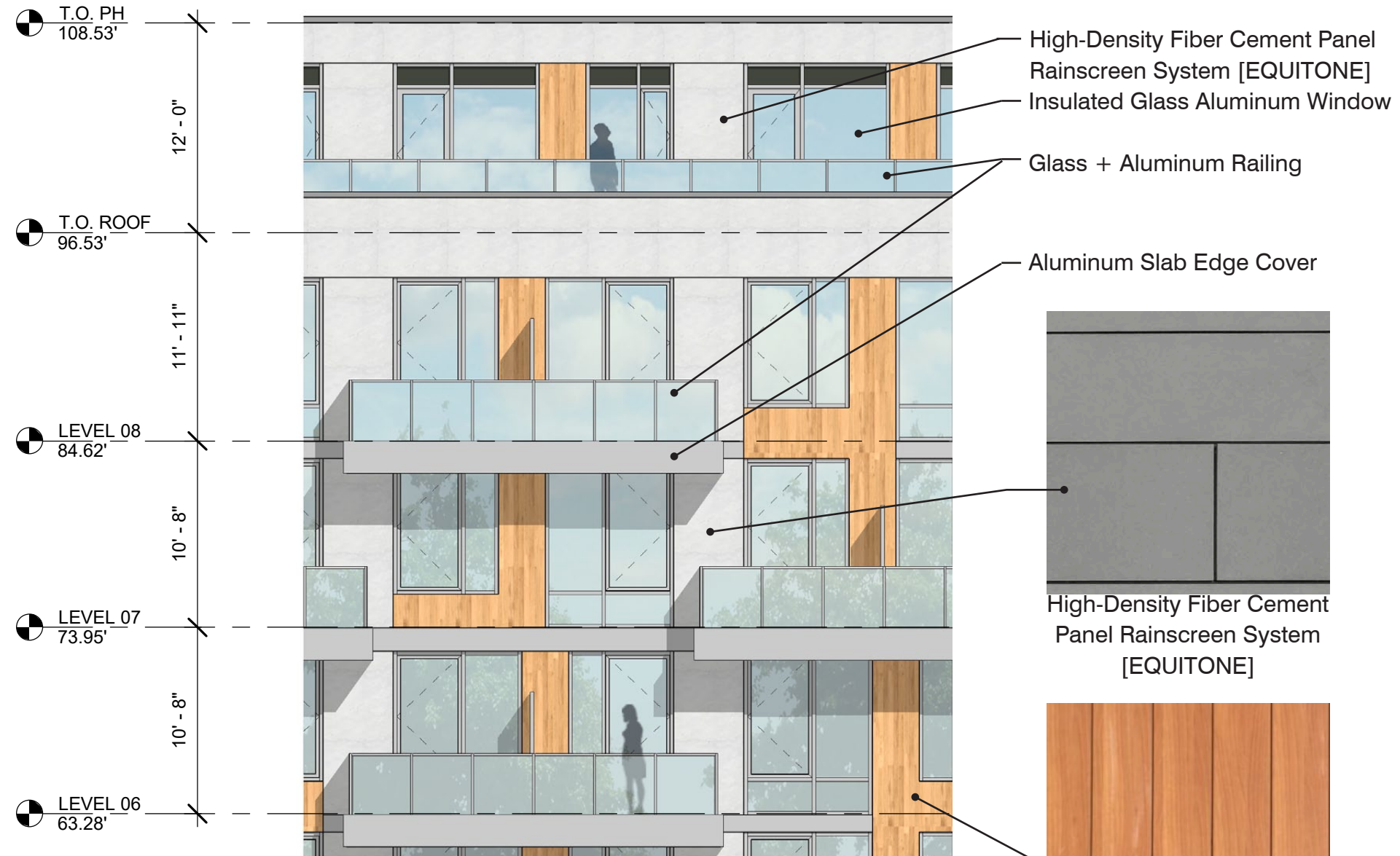

Partial Elevation

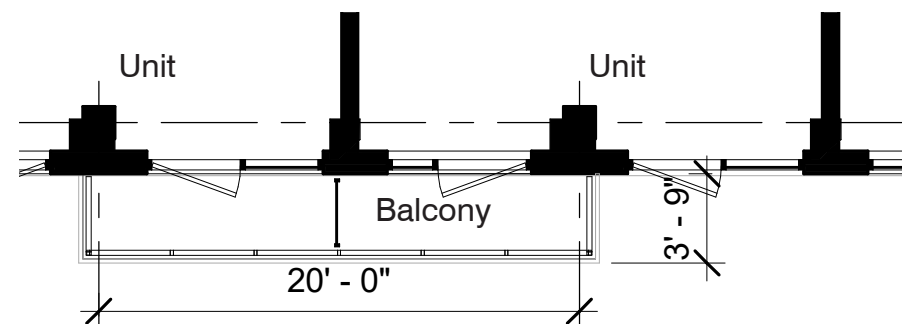

Partial Plan

River Point - 2100 2nd St, SW

Square 613 / Lot 10

Facade Materials: Facade Type C

May 16, 2017



A43

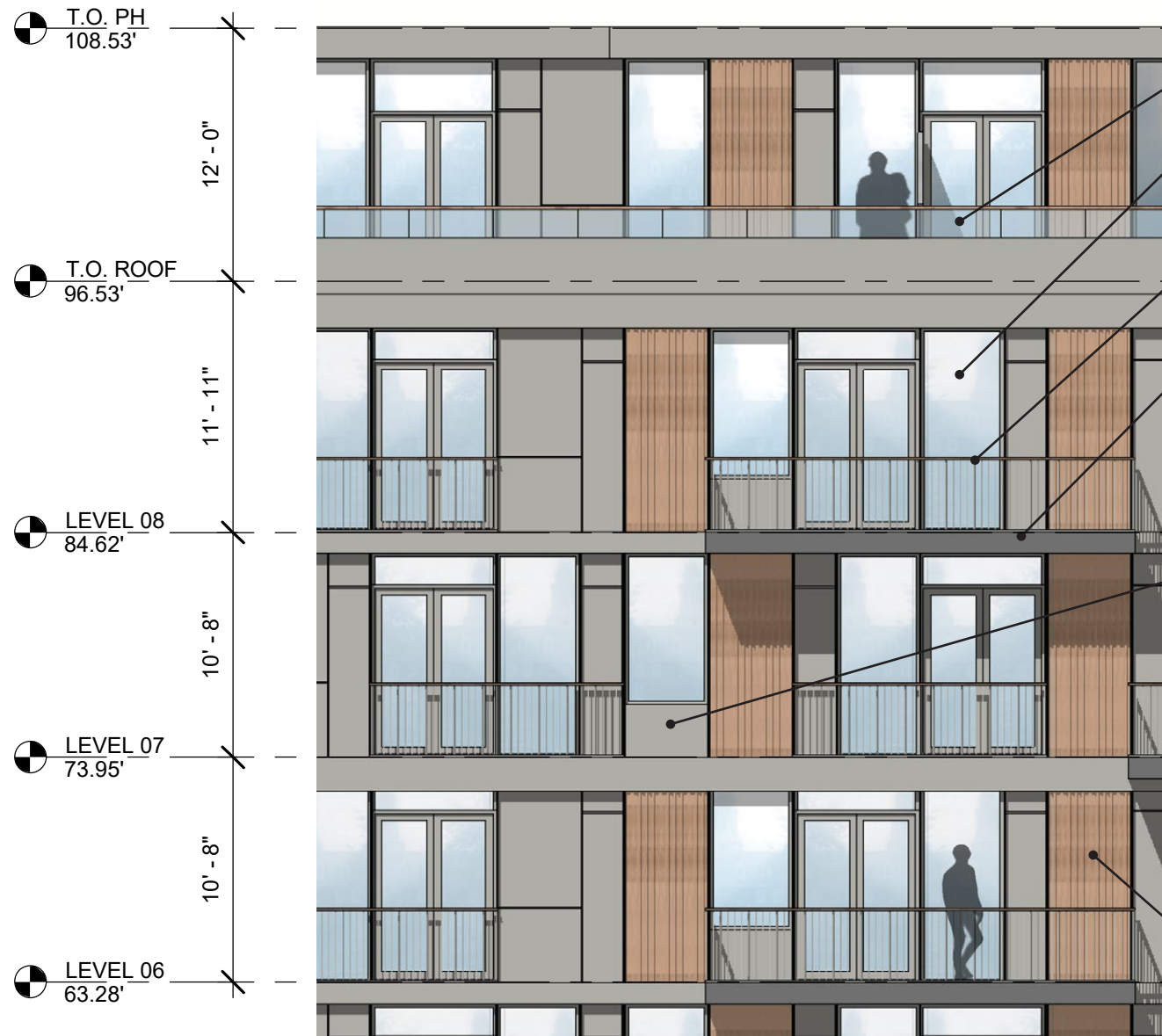

Partial Elevation

- Glass + Aluminum Railing
- Insulated Glass Aluminum Window
- Aluminum Balusters + Railing
- Aluminum Slab Edge Cover

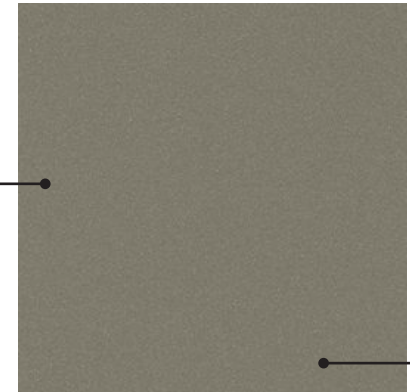

ACM Panel
Paint: Duranar XL - Summer Suede Metallic

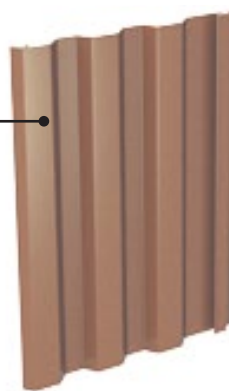

Corrugated Aluminium Siding
[CENTRIA - Concept Series]

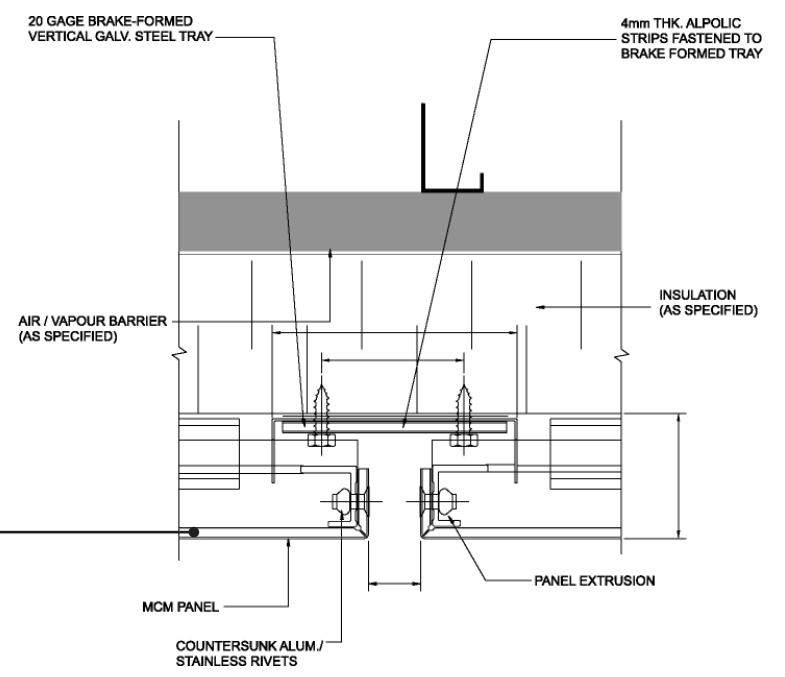

ACM Panel Rainscreen System
Joint Detail

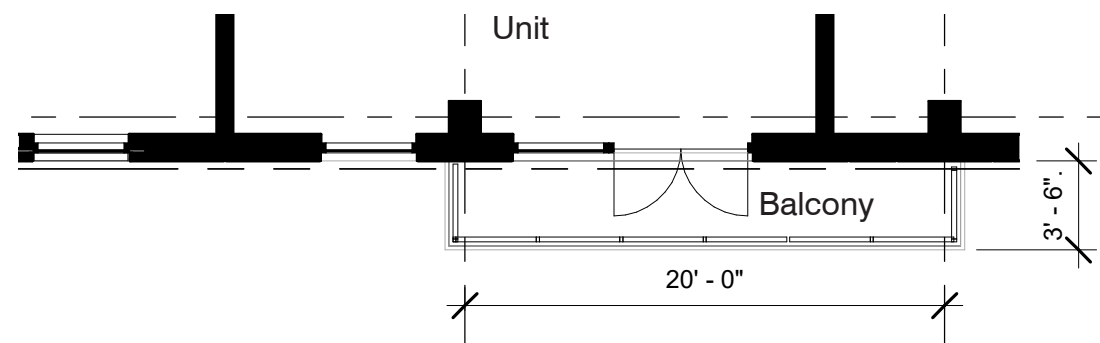

Partial Plan



River Point - 2100 2nd St, SW

Square 613 / Lot 10

Redering - 2nd Street (Southwest Corner)

May 16, 2017



A54

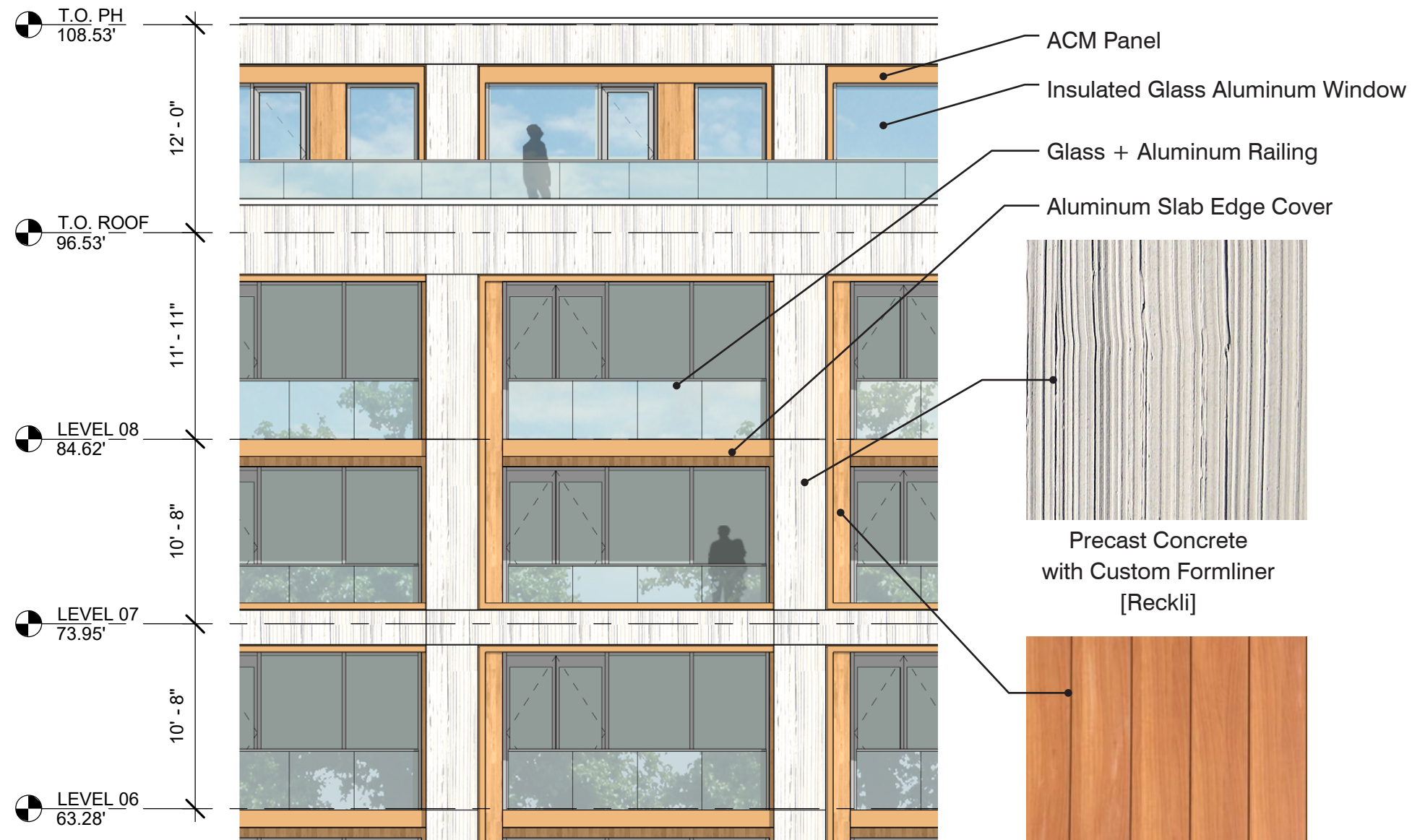

Partial Elevation

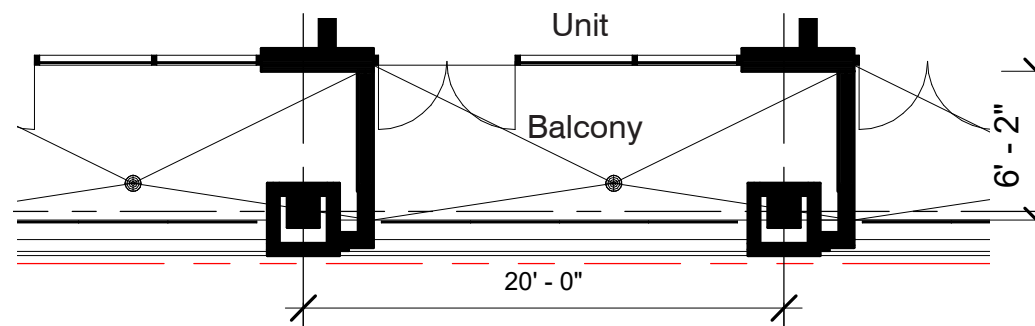

Partial Plan



River Point - 2100 2nd St, SW

Square 613 / Lot 10

Rendering - Northeast Corner (enlarged)

June 2, 2017



A53